



GDA General Duty LED Area Light

The Ironclad® General Duty Area fixture or G.D.A is designed primarily for correctional and behavioral applications. The fixture's extreme low profile and compact housing is made to withstand abuse and features a rimless edge providing a rugged lighting solution.

Specifications:

- Lumens: 3500 (34W)
- Light Engine CCT: 5000K, 4000K, 3500K, 2700K
- Life Hours: L70>75,000 Hours; Projected >100,000 Hours
- Footcandles: 35 ftc at the desk level; 22 ftc at the floor
- Voltage: Universal 120-277V
- Dimensions: 13" diameter x 1.93" tall
- Warranty: 5 year limited warranty

Certifications: IK10 Impact Rating, cULus, UL Damp Location, UL Wet Location

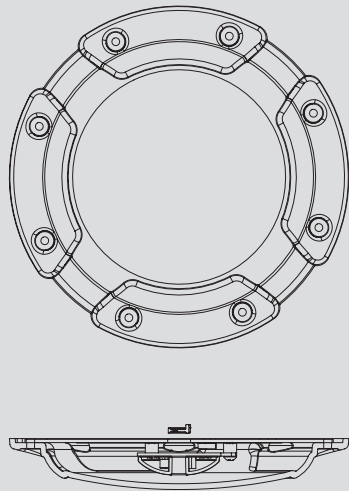

Fixture construction

- Lens is made of highly impact-resistant 1/4" thick polycarbonate with a minimum IK10 impact rating
- Aluminum heat sink to maintain thermal management
- Installation - Anchored flush onto ceiling with (8) recessed tamper-proof 1/4" stainless steel bolts or optional spike anchors or cinder block fasteners
- Hard wired direct to AC current; eliminating any failure points via driver
- No accessible parts or hinges
- No rusting or peeling paint

*Illuminating Engineering Society (IES), American Correctional Association (ACA) and Federal Bureau of Prisons (FBOP) recommended footcandle level is 20 ftc at the desk surface.



Manufactured in America with globally and domestically sourced components.

