



## Corner Pro

### Vandal-Resistant LED Corner Area Light

The Ironclad® Corner Pro fixture is designed to mount flush between the wall and ceiling. The heavy-gauge mounting box is able to withstand abuse, and drastically impede tampering, removal, or damage to the light fixture within the prison facility. The fixture itself utilizes a specially engineered .5" thick steel frame, and proprietary .5" thick cast low profile lens. There are no areas to hide contraband or openings to access the fixture. The optional count light LED module can be turned on and off as needed, depending on the application of the area being used.

#### Specifications:

- Lumens: 4200 (40W), 8400 (80W)
- Count Light Lumens: 530
- Light Engine CCT: 5000K, 4000K
- Count Light CCT: 2700K
- Life Hours: L70>75,000 hrs; Projected >100,000 hrs
- Footcandles: 35 ftc at desk level; 22 ftc at floor
- Voltage: Universal 120-277V
- Weight: 18.65 lbs.
- Dimensions: 26.5" long x 9.5" wide x 7" tall
- Warranty: 5 year limited warranty

**Certifications:** cULus, UL Damp Location, IK10 Impact Rating

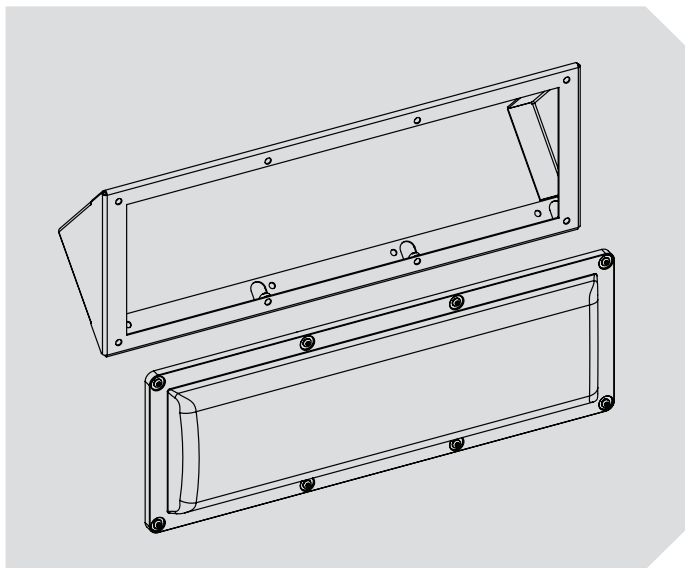

#### Fixture construction

- One piece frame - .500" thick steel, epoxy powder coated
- Lens - .500" thick cast, diffused translucent, highly engineered urethane, shore hardness D80+, tensile strength 5,400 psi, impact strength 55 in. lbs./ in.
- Aluminum heat sink to maintain thermal management
- Installation - Anchored flush onto ceiling with (8) recessed fasteners, tamper-proof 1/4" stainless steel bolts or cinder block fasteners.
- Hard wired direct to AC current; eliminating failure points external to fixture
- No accessible parts or hinges

\*Illuminating Engineering Society (IES), American Correctional Association (ACA) and Federal Bureau of Prisons (FBOP) recommended footcandle level is 20 ftc at the desk surface.



Manufactured in America with globally and domestically sourced components.

