

⚡ Wiring Diagram

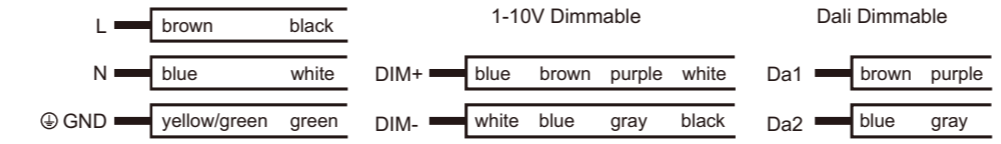

? Troubleshooting

Problem	Possible Cause	Solutions
LEDs stop working	The power line is improperly connected.	Reconnect the power cable.
	The power plug is loose.	Firmly plug the power in.
	The LED driver malfunctions.	Replace with new driver.
	The LED chip is damaged.	Replace with new LEDs.
LEDs flash on and off	The output of the driver is abnormal.	Replace with new driver.
	The LED chip breaks down.	Replace with new LED chip.

LED High Bay Light

Instruction Manual



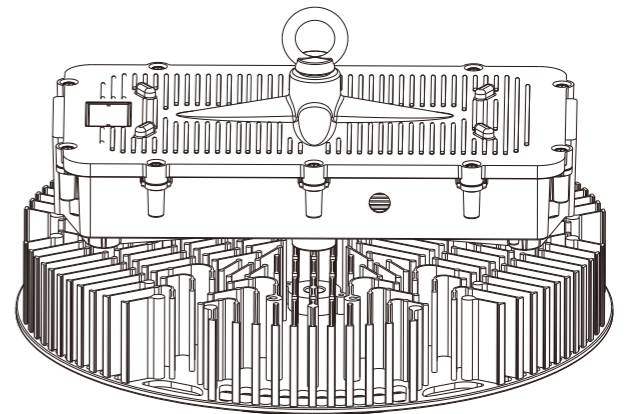

450W/600W



Reminder

We appreciate your purchase!
Please read the instruction manual before installation and keep it for future reference.



Warning

1. To avoid damage, falling, electric shock or fire, please do not modify the lamp or replace accessories without confirming with the supplier first.
2. Please authorize only qualified personnel to install the lamp and ensure they follow the instruction manual. Any improper installation might cause falling, electric shock, fire, or other injury, damage or hazard.
3. Please disconnect power before installation or any maintenance of the lamp.
4. Please disconnect power if it begins to smoke or emit odors, since fire or electric shock may occur. Ask qualified person to inspect and maintain the luminaire.
5. Please do not dismantle the lamp without the supplier's authorization.
6. Please do not touch the power supply when the lamp is operating.
7. The external flexible cable or cord of this luminaire cannot be replaced; if the cord is damaged, the luminaire shall be destroyed.
8. Terminal block not included. Instal lation may require advice from a qualified person.
9. The light source contained in this luminaire shall only be replaced by the manufacturer or his service agent or a similar qualified person.
10. Only to be installed outside arms reach.
11. For use in environments where an accumulation of non-conductive dust on the luminaire may be expected.
12. Mounting heights of lights not higher than 30m.
13. Do not install it in narrow and closed area.

Caution risk of electric shock



Technical Parameters

Product Specifications	450W	600W
Input Voltage	AC100-240V / AC100-277V / AC200-240V / AC220-240V / AC277-480V	
Power Frequency	50 / 60Hz	
Outlook Dimensions	∅454 x 263mm (∅17.87" x 10.35")	
Luminaire Net Weight	12.8±0.3kg (28.22±0.66Lbs)	13.5±0.3kg (29.76±0.66Lbs)
Working Temperature	-30°C to +50°C (-22°F to +122°F)	
Storing Temperature	-40°C to +70°C (-40°F to +158°F)	



Installation Instructions

A. Loop hanging installation

Physical Dimensions(mm/inch)

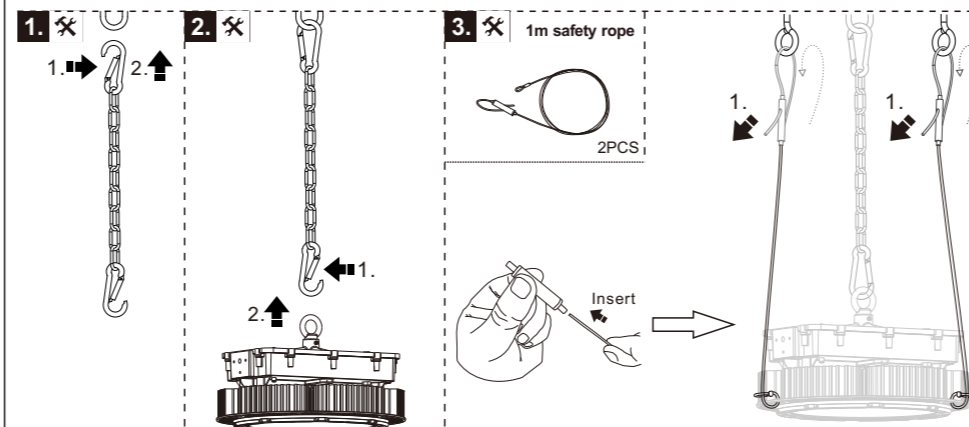
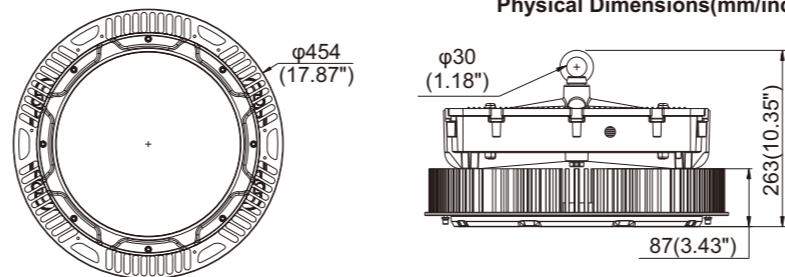

B. Bracket mounting installation

Physical Dimensions(mm/inch)

