



IMPORTANT SAFEGUARDS READ AND FOLLOW ALL SAFETY INSTRUCTIONS.

When using electrical equipment, basic safety precautions should always be followed including the following:

- **DISCONNECT AC POWER SUPPLY BEFORE SERVICING.**
- Installation and servicing of this equipment should be performed by qualified service personnel only.
- Ensure that the electrical wiring conforms to the National Electrical Code NEC® and local regulations if applicable.
- Not suitable for use in wet locations.
- “Class 1” wiring for dimming wire.
- Do not mount near gas or electrical heaters.
- Equipment should be mounted in locations and at heights where it will not be readily subjected to tampering by unauthorized personnel.
- The use of accessory equipment not recommended by the manufacturer may cause an unsafe condition.
- Any modification or use of non-original components will void the warranty and product liability.
- Do not use this equipment for other than intended use.

SAVE THESE INSTRUCTIONS!

Recessed Grid Ceiling Installation

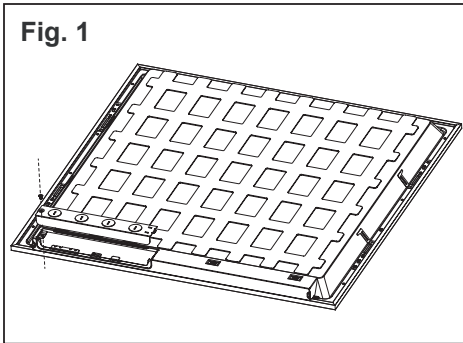

1. Carefully unpack fixture from packaging and check contents. (Fig. 1)

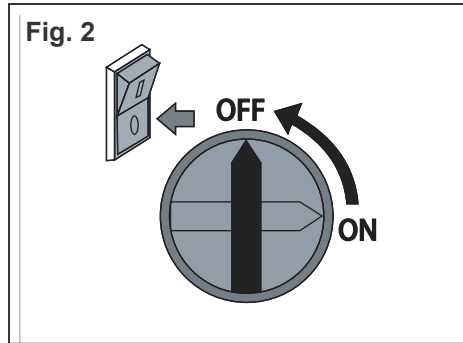

2. Make sure power is turned off at the circuit breaker. (Fig. 2)

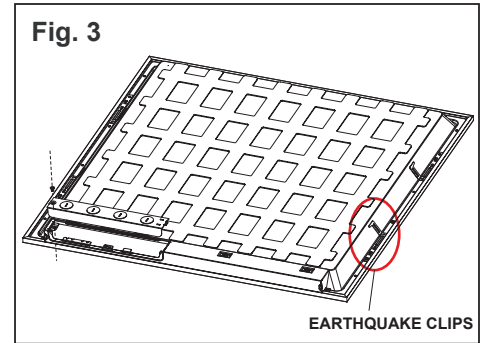

3. Locate all four earthquake clips on the back of the luminaire. Twist each tab away from the luminaire and test them on the T-bar. (Fig. 3)

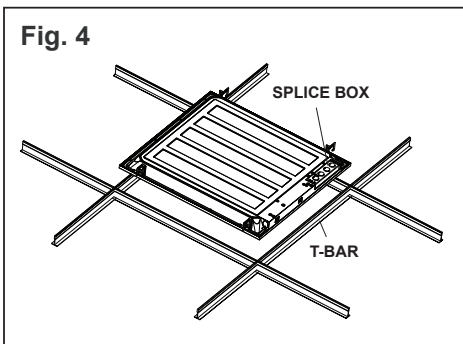

4. Place the luminaire on the T-bar of the ceiling suspension system in the desired location. (Fig. 4)

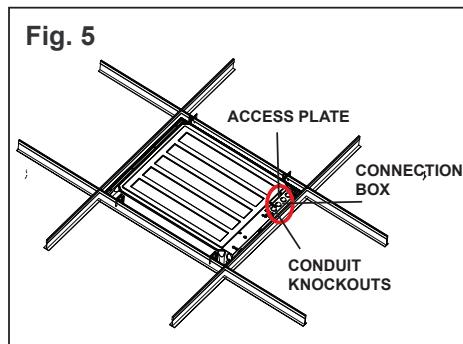

5. Open the fixture J-box by removing the access plate and make electrical connections. (Fig. 5 and **Electrical Connections** section). Make sure to firmly secure conduit to the access plate before replacing the access plate to the fixture J-box when complete.

Recessed Grid Ceiling Installation, Continued

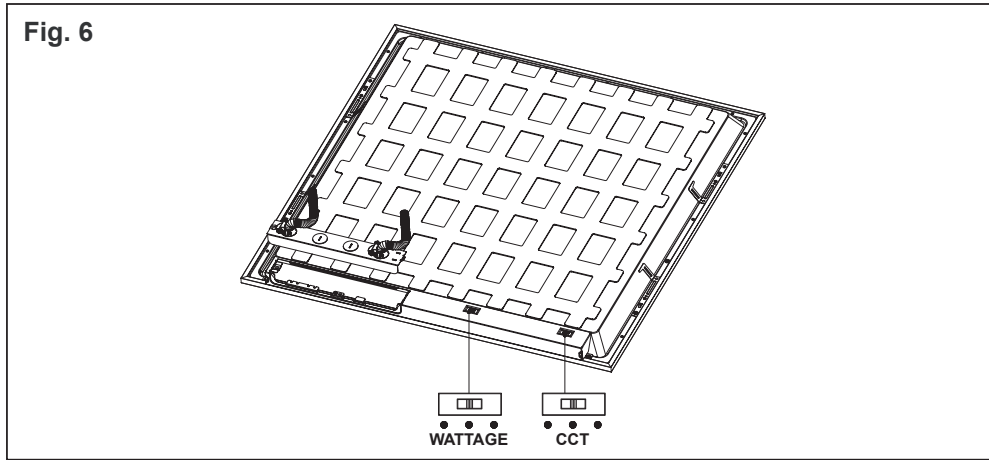

6. Select the CCT and wattage you need by adjusting the switches on the side of the connection box. (Fig. 6)

2x2 & 1x4 setting options: 20W-30W-40W, 3500K-4000K-5000K.
 2x4 setting options: 30W-40W-50W, 3500K-4000K-5000K.

Electrical Connections

Make electrical connections per the **Wiring Diagrams**. (Fig. 7 and 8)

Note: If dimming wires are not used make sure they are capped.
 This fixture auto adjusts for voltages between 120-277VAC.

Fig. 7 - Standard Wiring Diagram

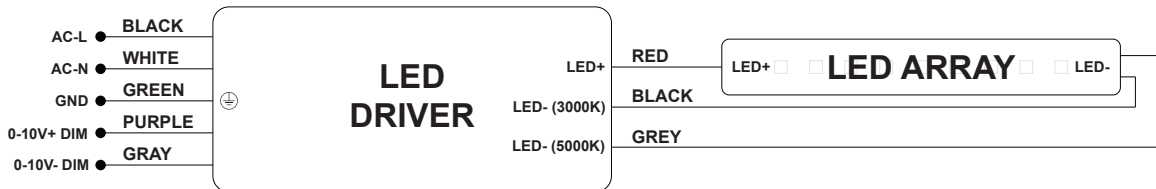
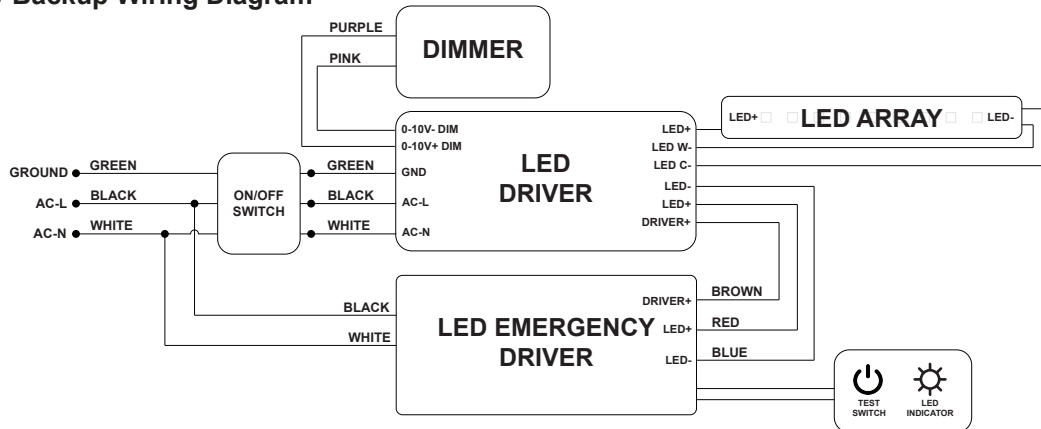

Fig. 8 - Battery Backup Wiring Diagram



Battery Back-up Information and Operation

1. Make sure battery is connected prior to closing fixture.
2. When power is turned ON for the first time, press the test button for 1 second to activate.
3. Battery requires up to 24 hours to fully charge after connecting to unswitched line power.
4. Battery backup has a momentary test switch with a red indicator light.
 - Red indicator light ON: Indicates there is unswitched power to the battery backup and it is in charging mode or fully charged
 - Red indicator light OFF: Battery backup is in discharging mode and there is no power to the unswitched line. Fixture LEDs illuminated by battery power.
5. Pressing the test button when main supply is on simulates loss of power. The red indicator light should turn OFF and the fixture LEDs should illuminate under battery power.

Troubleshooting

If the unit does not turn "ON".

1. Check incoming voltage to the LED driver. On the Switch/Un-switch line it must be a minimum of 120VAC and no greater than 277VAC.
2. Are all LEDs on the light engine "OFF"? If so, the LED driver may be defective. Using a voltmeter, check to see if the voltage is present at the output of the power supply. If low or no voltage is found, contact technical support.
3. If any individual LEDs are "OFF" the LED light engine may be defective. Please have the Trace-Lite catalog number of the fixture off the light engine available when you contact technical support.